

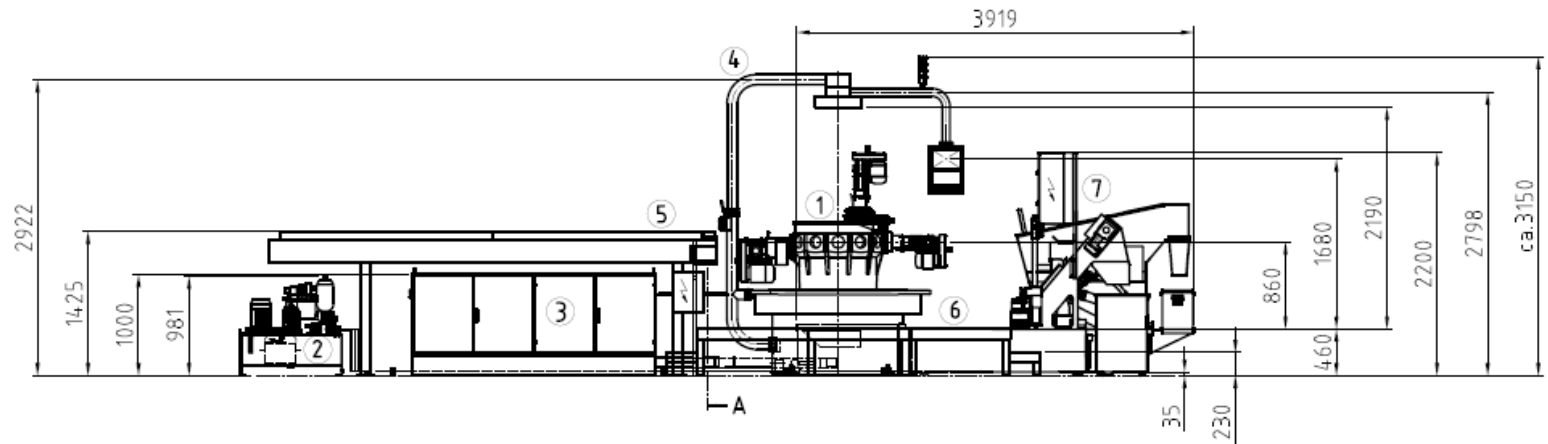

(1:25)

Ansicht: A



Zentralschmierung mit Leckölbehälter

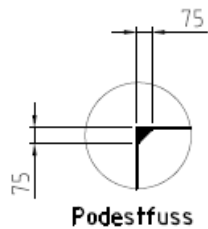

(1:25)

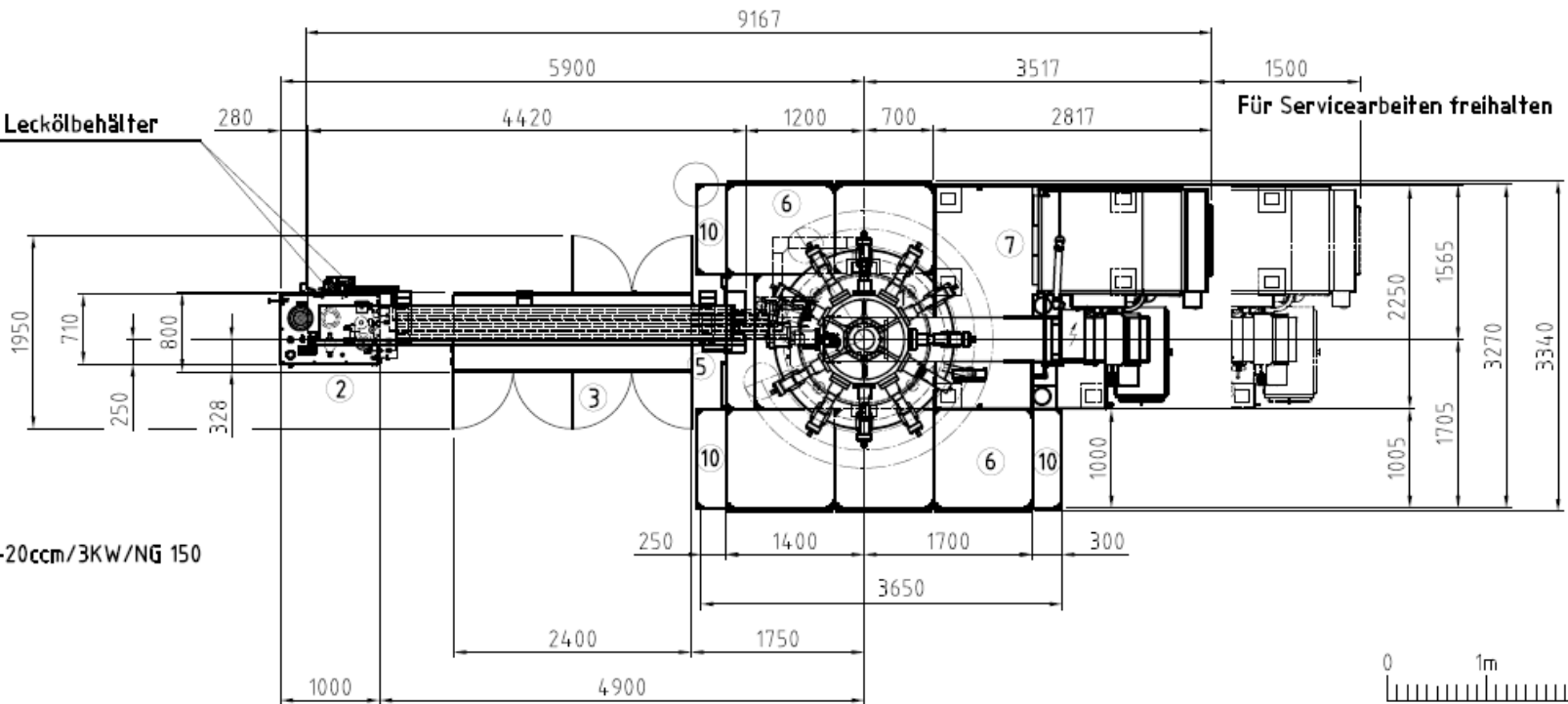

1 Hydromat HW 25/12

2 Hydraulikaggregat 4 L/Sp-20ccm/3KW/NG 150

3 Steuerschrank

4 Galgen + Hängetasten OP

5 Lademagazin 4.2m

6 Podest

7 Kühlmittelanlage VRF 2250 Liter

Layout

HW25-12: Standard

Lademagazin: 4 Meter

Kühlmittelanlage: VRF-Anlage

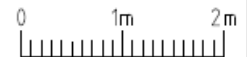

**HME TRADING AG**

Your Partner for Transfer Machine Technology