

(1:25)

Ansicht: A

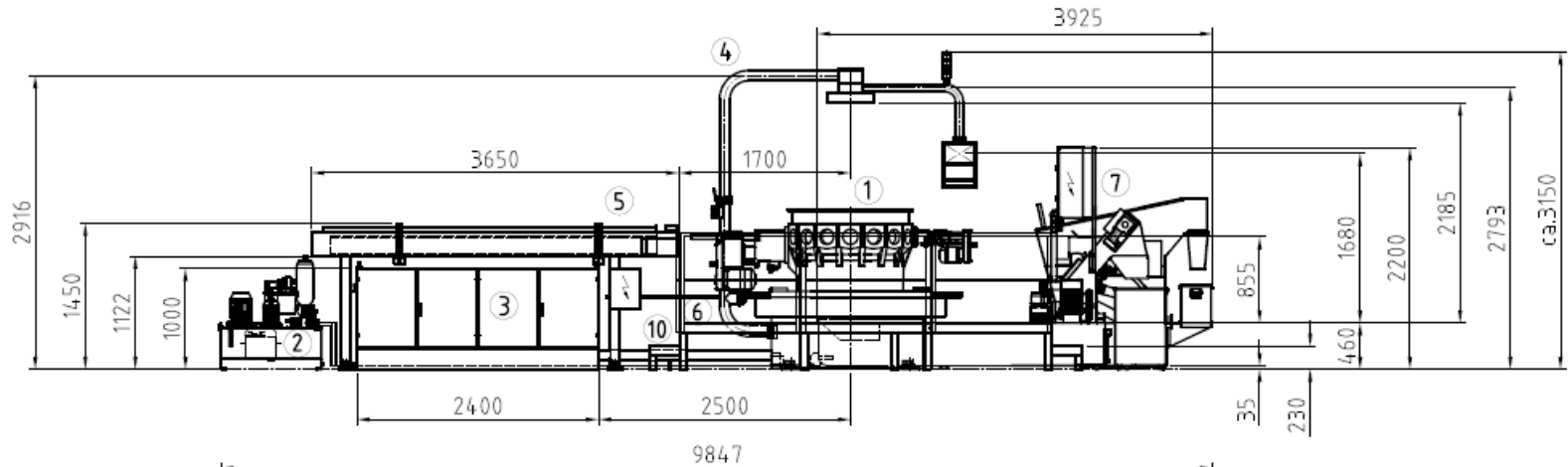

Zentralschmierung mit Leckölbehälter

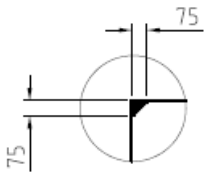

Podestfuss

(1:25)

Für Servicearbeiten freihalten

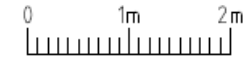
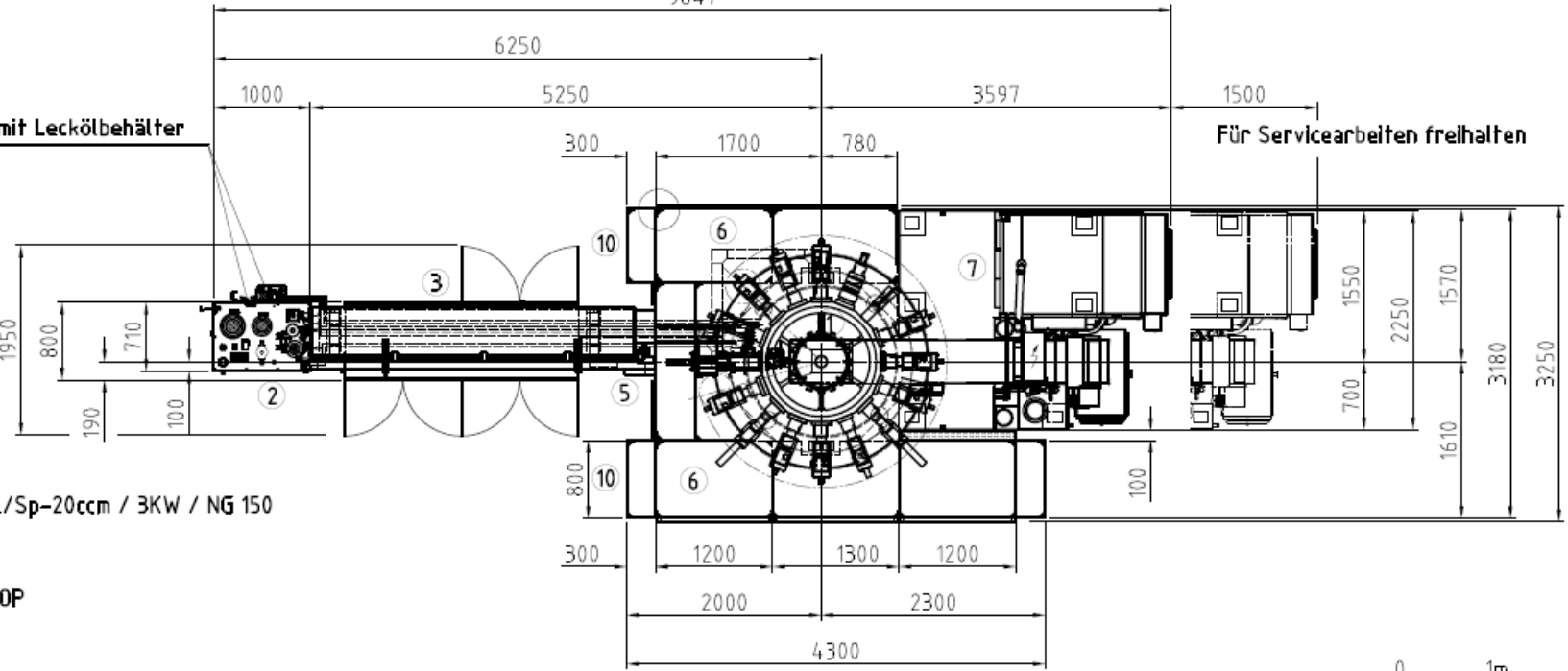

- 1 Hydromat HB 32/16
- 2 Hydraulikaggregat 10 L/Sp-20ccm / 3KW / NG 150
- 3 Steuerschrank
- 4 Galgen + Hängeraster OP
- 5 Lademagazin 3.2m
- 6 Podest
- 7 Kühlmittelanlage VRF 2250 Liter
- 10 Treppe

Layout
 HW32-16: Standard
 Lademagazin: 3 Meter
 Kühlmittelanlage: VRF-Anlage

HME TRADING AG
 Your Partner for Transfer Machine Technology